

117-2250-90

PCB Piezotronics Inc. claims proprietary rights in the information disclosed hereon. Neither it nor any reproduction thereof will be disclosed to others without the written consent of PCB Piezotronics Inc.

REVISIONS		
REV	DESCRIPTION	DIN
G	UPDATED 065A19 NOTE	50698

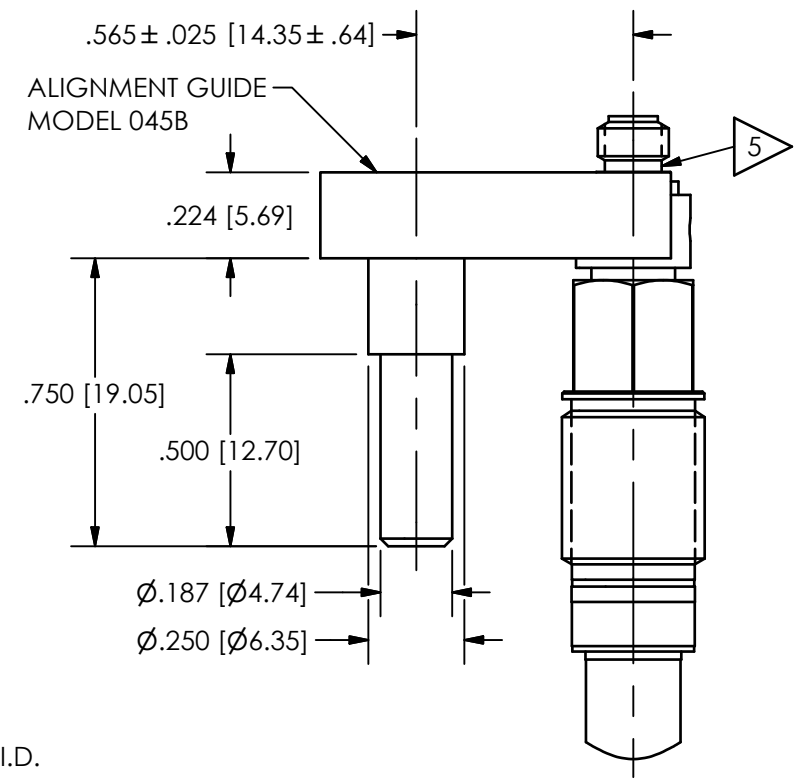
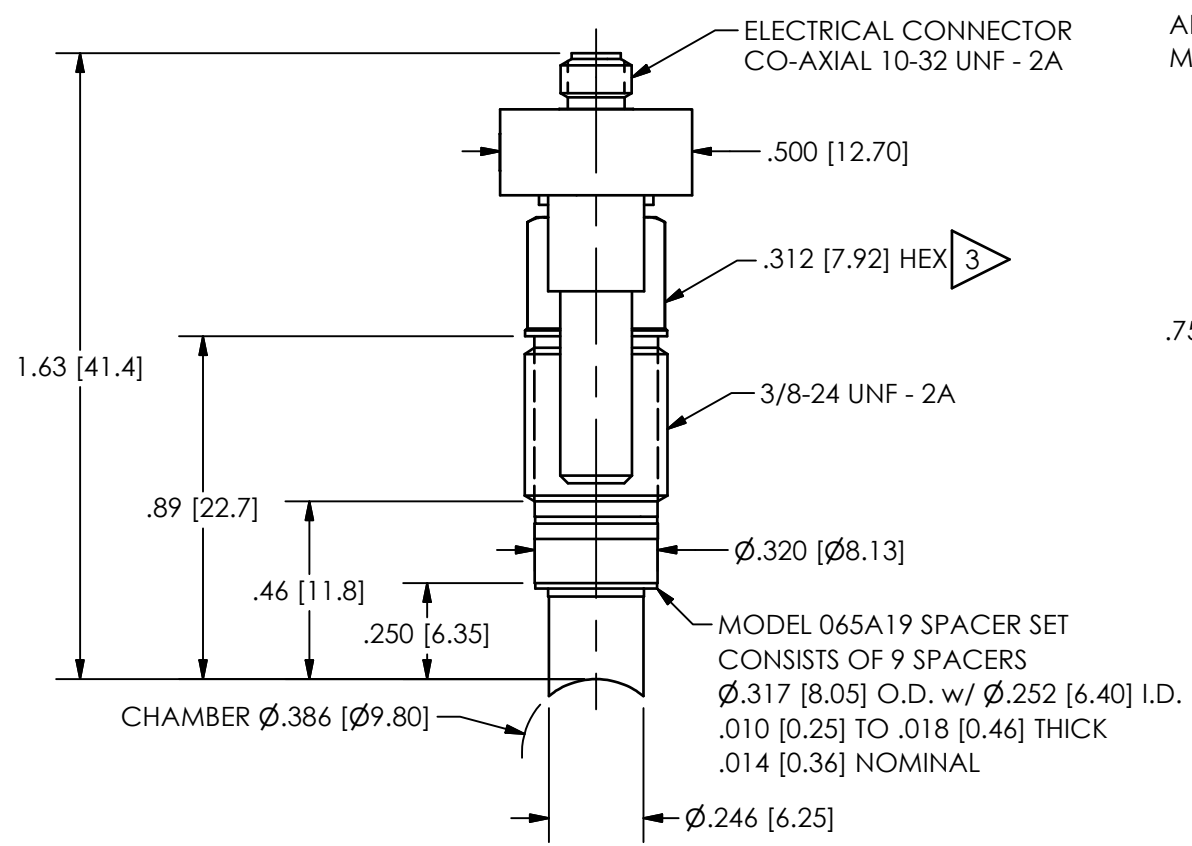

2 ϕ .2500 \pm .0005 [6.350 \pm .013] THRU ONE WALL
 \perp ϕ .332 [8.43] ∇ .569 [14.45]
 3/8-24 UNF-2B ∇ .450 [11.43]

ϕ .177 [4.50] ∇ .400 [10.16]
 ϕ .1875 \pm .0005 [4.763 \pm .013] ∇ .400 [10.16]

4 CENTERLINE OF SENSOR HOLE TO BE PARALLEL WITH ALIGNMENT HOLE TO WITHIN \pm 15 MIN

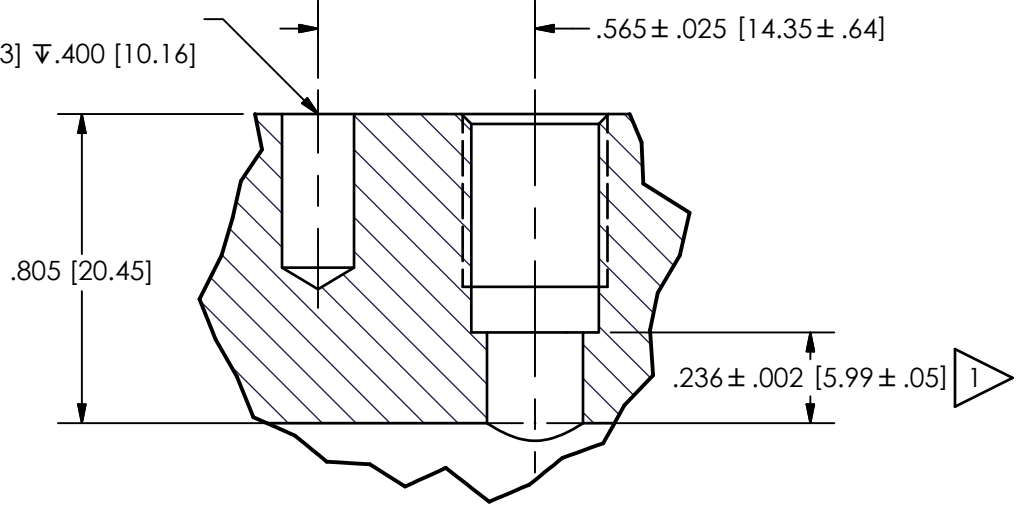
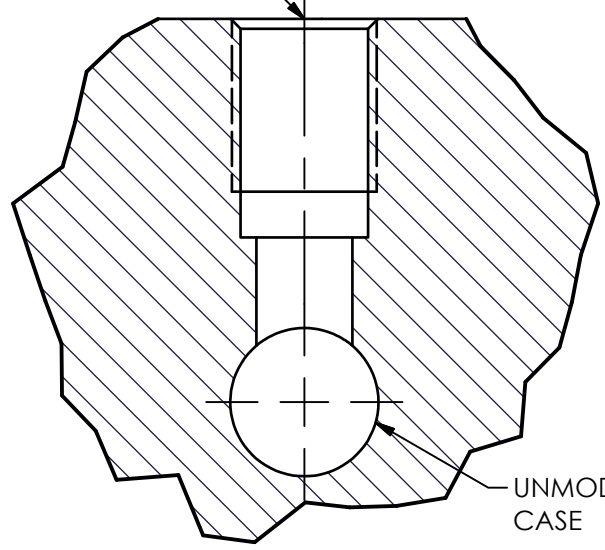

- 5 LOCATE YELLOW DOT TOWARD CASE MOUTH
- 4 ALIGNMENT HOLE MAY BE LOCATED EITHER FORE OR AFT OF SENSOR MOUNTING HOLE
- 3 MOUNTING TORQUE ON .312 [7.92] HEX: 5-10 FT LBS [6.8-13.6 NEWTON METERS]
- 2 CENTERLINE OF ϕ .2500 [6.350] HOLE MUST INTERSECT CENTERLINE OF CHAMBER BORE WITHIN .001 [.23]
- 1 HOLD THIS DIMENSION TO OBTAIN FLUSH MOUNT

UNLESS OTHERWISE SPECIFIED TOLERANCES ARE:		DRAWN		CHECKED		ENGINEER	
DIMENSIONS IN INCHES	DIMENSIONS IN MILLIMETERS [IN BRACKETS]	JJF	2/10/21	KSR	2/10/21	MJK	2/10/21
DECIMALS XX \pm .01 XXX \pm .005	DECIMALS X \pm .3 XX \pm .13	TITLE					
ANGLES \pm 2 DEGREES	ANGLES \pm 2 DEGREES	INSTALLATION DRAWING MODEL 117B25 CONFORMAL BALLISTIC SENSOR					
FILLETS AND RADII .003 - .005	FILLETS AND RADII 0.07 - 0.13	CODE IDENT. NO. 52681		DWG. NO. 117-2250-90		3425 WALDEN AVE. DEPEW, NY 14043 (716) 684-0001 E-MAIL: sales@pcb.com	
		SCALE: 2X		SHEET 1 OF 1			