



**Model 138A50**

**Tourmaline ICP® underwater blast sensor, 7.6" length, 50k psi, 0.1 mV/psi**

**Installation and Operating Manual**

**For assistance with the operation of this product,  
contact the PCB Piezotronics, Inc.**

**Toll-free: 716-684-0001**

**24-hour SensorLine: 716-684-0001**

**Fax: 716-684-0987**

**E-mail: [info@pcb.com](mailto:info@pcb.com)**

**Web: [www.pcb.com](http://www.pcb.com)**



## Repair and Maintenance

PCB guarantees Total Customer Satisfaction through its “Lifetime Warranty Plus” on all Platinum Stock Products sold by PCB and through its limited warranties on all other PCB Stock, Standard and Special products. Due to the sophisticated nature of our sensors and associated instrumentation, **field servicing and repair is not recommended and, if attempted, will void the factory warranty.**

Beyond routine calibration and battery replacements where applicable, our products require no user maintenance. Clean electrical connectors, housings, and mounting surfaces with solutions and techniques that will not harm the material of construction. Observe caution when using liquids near devices that are not hermetically sealed. Such devices should only be wiped with a dampened cloth—never saturated or submerged.

In the event that equipment becomes damaged or ceases to operate, our Application Engineers are here to support your troubleshooting efforts 24 hours a day, 7 days a week. Call or email with model and serial number as well as a brief description of the problem.

## Calibration

Routine calibration of sensors and associated instrumentation is necessary to maintain measurement accuracy. We recommend calibrating on an annual basis, after exposure to any extreme environmental influence, or prior to any critical test.

PCB Piezotronics is an ISO-9001 certified company whose calibration services are accredited by A2LA to ISO/IEC 17025, with full traceability to SI through N.I.S.T. In addition to our standard calibration services, we also offer specialized tests, including: sensitivity at elevated or cryogenic temperatures, phase response, extended high or low frequency response, extended range, leak testing, hydrostatic pressure testing, and others. For more information, contact your local PCB Piezotronics distributor, sales representative, or factory customer service representative.

## Returning Equipment

If factory repair is required, our representatives will provide you with a Return Material Authorization (RMA) number, which we use to reference any information you have already provided and expedite the repair process. This number should be clearly marked on the outside of all returned package(s) and on any packing list(s) accompanying the shipment.

## Contact Information

PCB Piezotronics, Inc.  
3425 Walden Ave.  
Depew, NY14043 USA  
Toll-free: (800) 828-8840  
24-hour SensorLine: (716) 684-0001  
General inquiries: [info@pcb.com](mailto:info@pcb.com)  
Repair inquiries: [rma@pcb.com](mailto:rma@pcb.com)

For a complete list of distributors, global offices and sales representatives, visit our website, [www.pcb.com](http://www.pcb.com).

## Safety Considerations

This product is intended for use by qualified personnel who recognize shock hazards and are familiar with the precautions required to avoid injury. While our equipment is designed with user safety in mind, the protection provided by the equipment may be impaired if equipment is used in a manner not specified by this manual.

Discontinue use and contact our 24-Hour Sensorline if:

- Assistance is needed to safely operate equipment
- Damage is visible or suspected
- Equipment fails or malfunctions

For complete equipment ratings, refer to the enclosed specification sheet for your product.

## Definition of Terms and Symbols

The following symbols may be used in this manual:



### **DANGER**

Indicates an immediate hazardous situation, which, if not avoided, may result in death or serious injury.

**CAUTION**

Refers to hazards that could damage the instrument.

**NOTE**

Indicates tips, recommendations and important information. The notes simplify processes and contain additional information on particular operating steps.

**The following symbols may be found on the equipment described in this manual:**



This symbol on the unit indicates that high voltage may be present. Use standard safety precautions to avoid personal contact with this voltage.



This symbol on the unit indicates that the user should refer to the operating instructions located in the manual.



This symbol indicates safety, earth ground.



PCB工业监视和测量设备 - 中国RoHS2公布表

PCB Industrial Monitoring and Measuring Equipment - China RoHS 2 Disclosure Table

部件名称	有害物质					
	铅 (Pb)	汞 (Hg)	镉 (Cd)	六价铬 (Cr(VI))	多溴联苯 (PBB)	多溴二苯醚 (PBDE)
住房	0	0	0	0	0	0
PCB板	X	0	0	0	0	0
电气连接器	0	0	0	0	0	0
压电晶体	X	0	0	0	0	0
环氧	0	0	0	0	0	0
铁氟龙	0	0	0	0	0	0
电子	0	0	0	0	0	0
厚膜基板	0	0	X	0	0	0
电线	0	0	0	0	0	0
电缆	X	0	0	0	0	0
塑料	0	0	0	0	0	0
焊接	X	0	0	0	0	0
铜合金/黄铜	X	0	0	0	0	0
本表格依据 SJ/T 11364 的规定编制。						
0：表示该有害物质在该部件所有均质材料中的含量均在 GB/T 26572 规定的限量要求以下。						
X：表示该有害物质至少在该部件的某一均质材料中的含量超出 GB/T 26572 规定的限量要求。						
铅是欧洲RoHS指令2011/65/ EU附件三和附件四目前由于允许的豁免。						

CHINA RoHS COMPLIANCE

Component Name	Hazardous Substances					
	Lead (Pb)	Mercury (Hg)	Cadmium (Cd)	Chromium VI Compounds (Cr(VI))	Polybrominated Biphenyls (PBB)	Polybrominated Diphenyl Ethers (PBDE)
Housing	O	O	O	O	O	O
PCB Board	X	O	O	O	O	O
Electrical Connectors	O	O	O	O	O	O
Piezoelectric Crystals	X	O	O	O	O	O
Epoxy	O	O	O	O	O	O
Teflon	O	O	O	O	O	O
Electronics	O	O	O	O	O	O
Thick Film Substrate	O	O	X	O	O	O
Wires	O	O	O	O	O	O
Cables	X	O	O	O	O	O
Plastic	O	O	O	O	O	O
Solder	X	O	O	O	O	O
Copper Alloy/Brass	X	O	O	O	O	O

This table is prepared in accordance with the provisions of SJ/T 11364.

O: Indicates that said hazardous substance contained in all of the homogeneous materials for this part is below the limit requirement of GB/T 26572.

X: Indicates that said hazardous substance contained in at least one of the homogeneous materials for this part is above the limit requirement of GB/T 26572.

Lead is present due to allowed exemption in Annex III or Annex IV of the European RoHS Directive 2011/65/EU.

# OPERATION MANUAL FOR Series 138

1

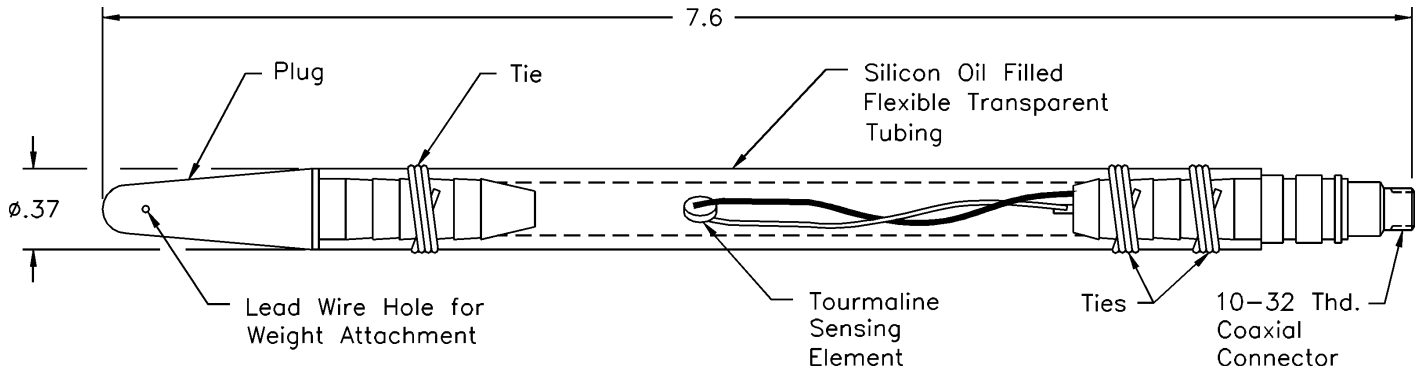

**Series 138 Standard Length, with Lead Wire Hole for Attaching Weights**

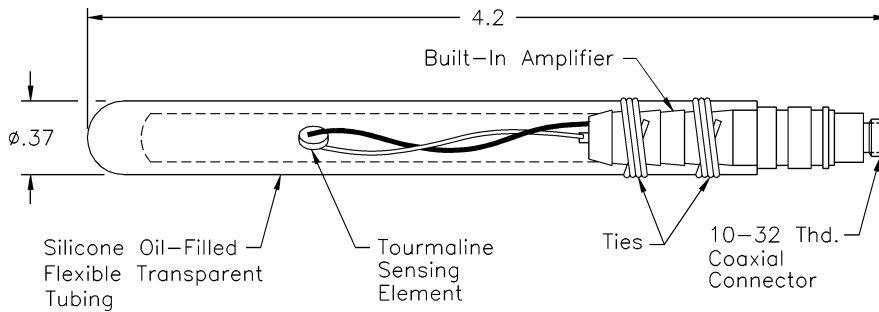

**Series 138 Short Length, One-Piece Molded Closed-End Tube**

## 1.0 INTRODUCTION

PCB Series 138 sensors are voltage mode tourmaline sensors designed for operation underwater or in liquids compatible with tygon and nylon. (See specification sheet in the back of the manual for range and sensitivity).

Series 138 features built-in ICP® amplifiers which convert the high-impedance voltage from the crystals into a low-impedance output voltage of less than 100 ohms. Power to operate the IC amplifier and the output signal is conducted over a single conductor coaxial cable with a shield serving as signal return. Special low-noise cables are not required.

Series 138 is used by the military for underwater explosive testing, commercial use in gasoline tanks and transformer shock wave applications. The sensors are ideal for monitoring dynamic pressures because they exhibit near non-resonant response.

The charge generated by deflection of the piezoelectric element when subjected to shock waves creates a voltage on the input capacitance at the gate of the amplifier. The amplifier, in conjunction with the source element, transforms this input into a low-impedance signal of equal amplitude. The DC bias that exists on the signal lead is blocked from the output by a coupling capacitor in the PCB signal conditioners.

Some models of the Series 138 feature a tygon tube closed at one end with conical-shaped delrin plug. The plug features a small hole for attachment of a weight. Other models feature a one-piece molded closed tube.

## **2.0 INSTALLATION, CABLE ATTACHMENT, AND SEALING THE CABLE/CONNECTOR ASSEMBLY**

Various methods are used to mount the 138 sensors for use in liquids. Care should be taken to prevent conductive liquids from entering the cable or connector assemblies, where they could cause corrosion, short-circuiting or degradation of insulation resistance.

For low-pressure (<500psi) dynamic measurements, a standard low-noise coaxial cable with an extruded teflon jacket and a 10-32 connector can be used. Heat shrink tubing, RTV silicon rubber, or sometimes silicone grease can make an adequate seal in an environment with low static pressure.

For high static pressures due to deep submersion or use in a pressure vessel, alternate methods of sealing the cable/connector may be required. A method of waterproofing the cable/connector assembly of a 138 which also provides protection to the cable is to put a flexible tube (plastic, tygon, etc.) around the cable and cable/connector assembly. Tie the tube at the metal housing with monofilament or fine steel wire. The opposite end of the tube must be above the level of the liquid or sealed around the cable to prevent liquid from entering the protective tubing. Filling the protective tube with a non-conducting liquid such as Dow Coming silicone oil can be done to prevent the tube from collapsing. This will also equalize pressure inside and outside the tubing, helping to prevent a conductive liquid (such as water) from entering.

In some blast applications, when using a standard 10-32 micro cable/connector, the high shock can flex the cable/connector joint enough to move the center pin of the 10-32 cable connector. This can cause noise on the output signal. Protecting the connection from shock may be required.

PCB Model 070A03 adaptor can be used to adapt the 10-32 micro jack on the 138 to a BNC jack. A heavier coaxial cable (eg. RG-58/U) can now be used in place of the micro cable. Because of the large mass of the 070A03 compared to the 10-32 jack, this connection should be sealed and protected from shock and turbulence. Putting a two to three inch diameter of duct seal, wrapped with a watertight tape, will seal the connection and provide shock protection at the cable/connector/ amplifier assembly.

PCB Model 070A09 Solder Connector Adaptor can also be used to attach a short length (~two to three inches) of ribbon cable to a 138. The ribbon cable can then be soldered to an extension cable. The ribbon cable and both solder connections should be sealed with a suitable waterproofing material. Various types of sealing materials such as polyethylene and flexane have been shown to be effective for sealing cables, connectors, etc.

## **2.1 MOUNTING OR SUSPENDING THE SENSOR**

After the cable/connector assembly is sealed, the sensor can be suspended in the liquid where the measurement is to take place. For low dynamic pressure measurements (less than 500 psi), models featuring a small hole in the conical end piece of the tube allow attachment of a light weight (~two lb.) to suspend the sensor in a vertical position.

The line should be of light material (monofilament, 15 lb. test) to enable it to break easily. This way, the sensor does not pull apart in the turbulence caused by the collapse of gas bubbles resulting from a shock wave.

For higher pressure dynamic measurements, alternate methods of suspending the sensor should be used to minimize damage from turbulence. Taping or attaching (with cable ties) the sensor amplifier housing to a braided steel wire is a method that is suited for use in higher dynamic pressure measurements.

The steel wire can have a weight attached to it to submerge the entire assembly. Tape or attach the coaxial cable loosely to the steel wire at ~one foot intervals. Attach a monofilament line (~50 lb. test) to the end of a steel wire braid, and let it hang down past the end of the sensor.

Attach a three to five lb. weight to the end of the monofilament and tape the sensor to the monofilament. See Image 1 for reference.

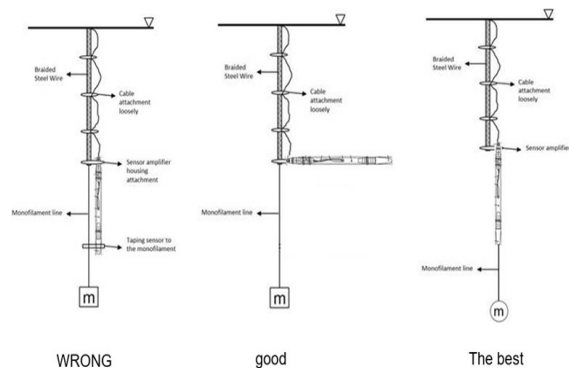

Image 1 – Installation Methods

### 3.0 OPERATION

It is necessary only to supply the sensor with a 2 to 20 mA constant current at +20 to +30 VDC through a current-regulating diode or equivalent circuit.

Most PCB signal conditioners have an adjustable current feature allowing a choice of input currents from 2 to 20 mA.

In general, for best resolution, choose the lower current ranges, and for driving long cables (to several thousand feet) use the higher current, up to 20 mA maximum. Line-impedance matching may be necessary to produce flat-frequency response over long (hundreds or thousands of feet) cables.

Switch power on and observe reading of bias monitoring voltmeter on front panel of the signal conditioner.

If indicator is in green section of indicator panel, the IC amplifier is producing proper bias (+8 to 14 VDC), cable connections are normal and the system is ready to operate.

If the needle moves to the red area of the fault monitor meter, output is zero and a short is indicated. Short could be located in amplifier, cable connectors, or power unit.

If the pointer moves into the yellow area of the fault monitor meter, an open circuit is indicated with full power supply voltage. An open circuit could be the result of a faulty amplifier, an open cable or open connectors.

Allow the sensor to stabilize for about one minute. A signal drift may occur when cable is connected to the readout instrument.

This drift occurs during charging of the coupling capacitor in the power unit. The signal will stabilize in several minutes.

### 4.0 CALIBRATION

Series 138 are calibrated dynamically using a drop weight tester. For best accuracy, use the calibration certificate supplied. Factory recalibration is available for a nominal charge.

### 5.0 POLARITY

This sensor series produces a positive-going output voltage for increasing pressure input. See the specification sheet for polarity of the sensor.

### 6.0 LOW-FREQUENCY RESPONSE

The low-frequency response of an ICP® system is determined by:

- 1.) The discharge time constant of the sensors.
- 2.) If AC-coupled at the power unit, the coupling time constant.



## **7.0 MAINTENANCE**

Observe the following precautions when using the sensor:

- 1.) Keep connections clean and dry.
- 2.) Do not exceed specified maximum range.
- 3.) Do not subject sensor to temperatures exceeding 100 °F.
- 4.) Do not apply voltage to sensor without current-limiting diodes or other current protection.
- 5.) Do not apply more than 20 mA of current to the sensor.

®ICP is a registered trademark of PCB Piezotronics, Inc.

Performance	ENGLISH	SI	
Measurement Range(for ±5V output)	50,000 psi	344,737 kPa	
Sensitivity(± 15 %)	0.1 mV/psi	0.015 mV/kPa	
Maximum Pressure	50,000 psi	344,737 kPa	
Resolution	1.0 psi	6.89 kPa	
Resonant Frequency	≥ 1,000 kHz	≥ 1,000 kHz	
Rise Time(Reflected)	≤ 1.5 μ sec	≤ 1.5 μ sec	
Low Frequency Response(- 5 %)	1.7 Hz	1.7 Hz	
Non-Linearity	≤ 2.0 % FS	≤ 2.0 % FS	[1]
<b>Environmental</b>			
Temperature Range(Operating)	-10 to +100 °F	-23 to +37.8 °C	
Maximum Vibration	20,000 g pk	196 140 m/s <sup>2</sup> pk	
<b>Electrical</b>			
Output Polarity(Positive Pressure)	Positive	Positive	
Discharge Time Constant(at room temp)	≥ 0.3 sec	≥ 0.3 sec	
Excitation Voltage	20 to 30 VDC	20 to 30 VDC	
Constant Current Excitation	2 to 20 mA	2 to 20 mA	
Output Impedance	≤ 100 Ohm	≤ 100 Ohm	
Output Bias Voltage	8 to 14 VDC	8 to 14 VDC	
<b>Physical</b>			
Sensing Element	Tourmaline	Tourmaline	
Housing Material	Stainless Steel	Stainless Steel	
Electrical Connector	10-32 Coaxial Jack	10-32 Coaxial Jack	
Weight	0.75 oz	21 gm	

**OPTIONAL VERSIONS**

Optional versions have identical specifications and accessories as listed for the standard model except where noted below. More than one option may be used.

**N** - Negative Output Polarity

**W** - Water Resistant Cable

**NOTES:**

[1]Zero-based, least-squares, straight line method.

[2]See PCB Declaration of Conformance PS023 for details.

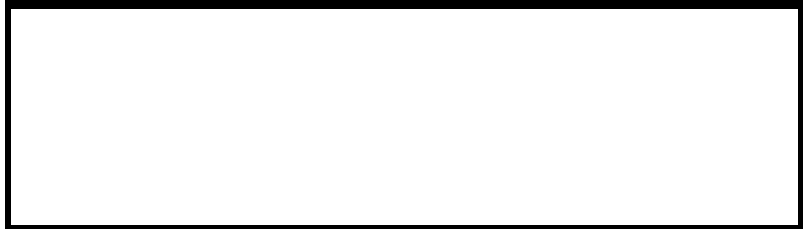

Entered: ND	Engineer: RPF	Sales: MV	Approved: BAM	Spec Number:
Date: 10/07/2021	Date: 10/07/2021	Date: 10/07/2021	Date: 10/07/2021	138-1500-80

**PCB PIEZOTRONICS**  
 Phone: 716-684-0001  
 Fax: 716-684-0987  
 E-Mail: info@pcb.com

3425 Walden Avenue, Depew, NY 14043

All specifications are at room temperature unless otherwise specified.  
 In the interest of constant product improvement, we reserve the right to change specifications without notice.  
 ICP® is a registered trademark of PCB Piezotronics, Inc.

138-1010-95

PCB Piezotronics Inc. claims proprietary rights in the information disclosed hereon. Neither it nor any reproduction thereof will be disclosed to others without written consent of PCB Piezotronics Inc.

APPLICATION

NEXT ASS'Y	USED ON	VAR

REVISIONS

REV	DESCRIPTION	ECN	DATE	APP'D
A	REVISED AND REDRAWN	5975	8/16/95	DM 8/95

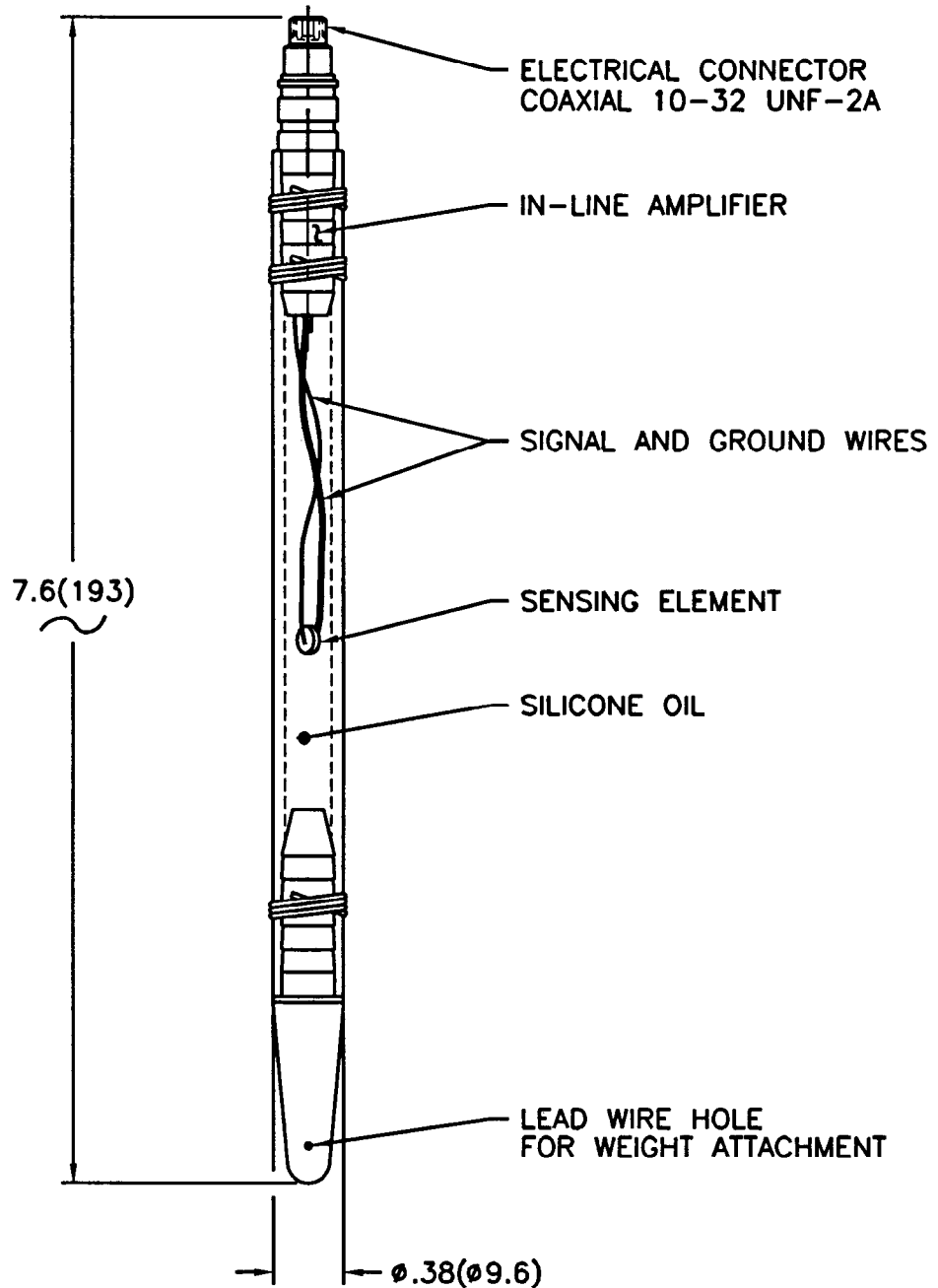

UNLESS SPECIFIED TOLERANCES

DIMENSIONS IN INCHES	DIMENSIONS IN MILLIMETERS (IN PARENTHESIS)
DECIMALS XX ±.01	DECIMALS XX ±0.3
XXX ±.005	XXX ±0.13
ANGLES ±2 DEGREES	ANGLES ±2 DEGREES
FILLETS AND RADII .003 - .005	FILLETS AND RADII (0.07 - 0.13)

DRAWN	JL	8/16/95	MFG	RTA	8/17/95
CHK'D	DM	8/17/95	ENGR	ZCR	8/17/95
APP'D	AI	8/21/95			

**PCB** PIEZOTRONICS, INC.  
3425 WALDEN AVE. DEPEW, NEW YORK 14043  
PHONE: (716) 684-0001

TITLE  
OUTLINE DRAWING  
MODEL 138A01,A05,A10,A25,A50  
UNDERWATER BLAST TRANSDUCER

CODE IDENT. NO.	DWG. NO.
52681	138-1010-95
SCALE: FULL	SHEET 1 OF 1